

4

3

2

1

REVISION HISTORY			
REV.	DESCRIPTION	DATE	DRAWN BY
1	ORIGINAL PRINT	11/8/2017	K. NEPOMUCENO
2	ADDED 516:1 AND 977:1 500HEX GEARMOTORS	4/24/2020	N. LAWRENCE
3	UPDATED MOUNT FLANGE SIZE TOLERANCE	2/3/2021	N. LAWRENCE

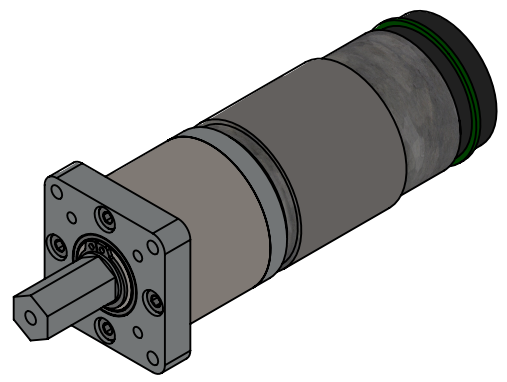

RATIO 27:1
(am-3654)

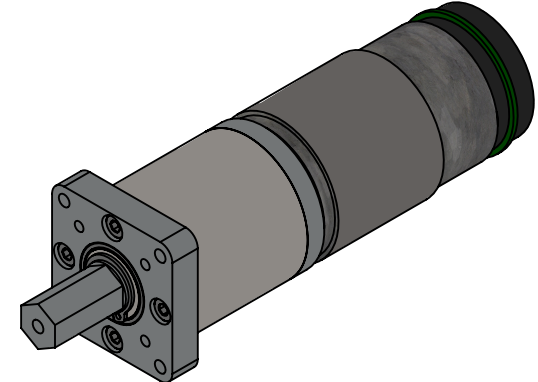

RATIO 71:1
(am-3655)

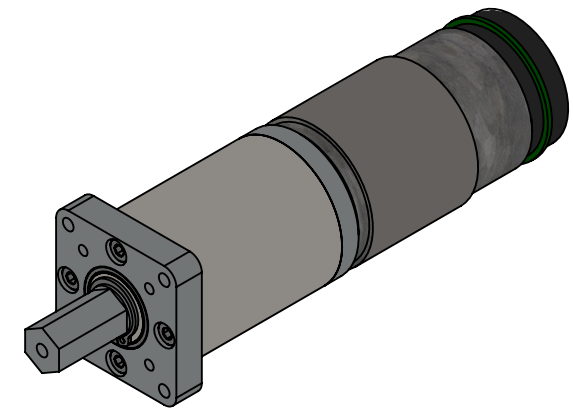

RATIO 188:1 (am-3656)
RATIO 516:1 (am-4250)

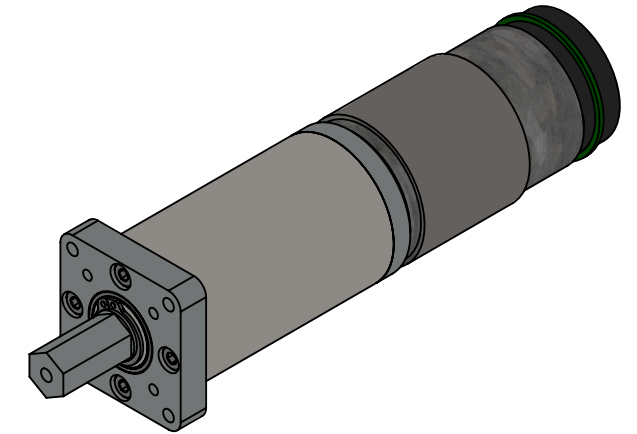

RATIO 977:1
(am-4270)

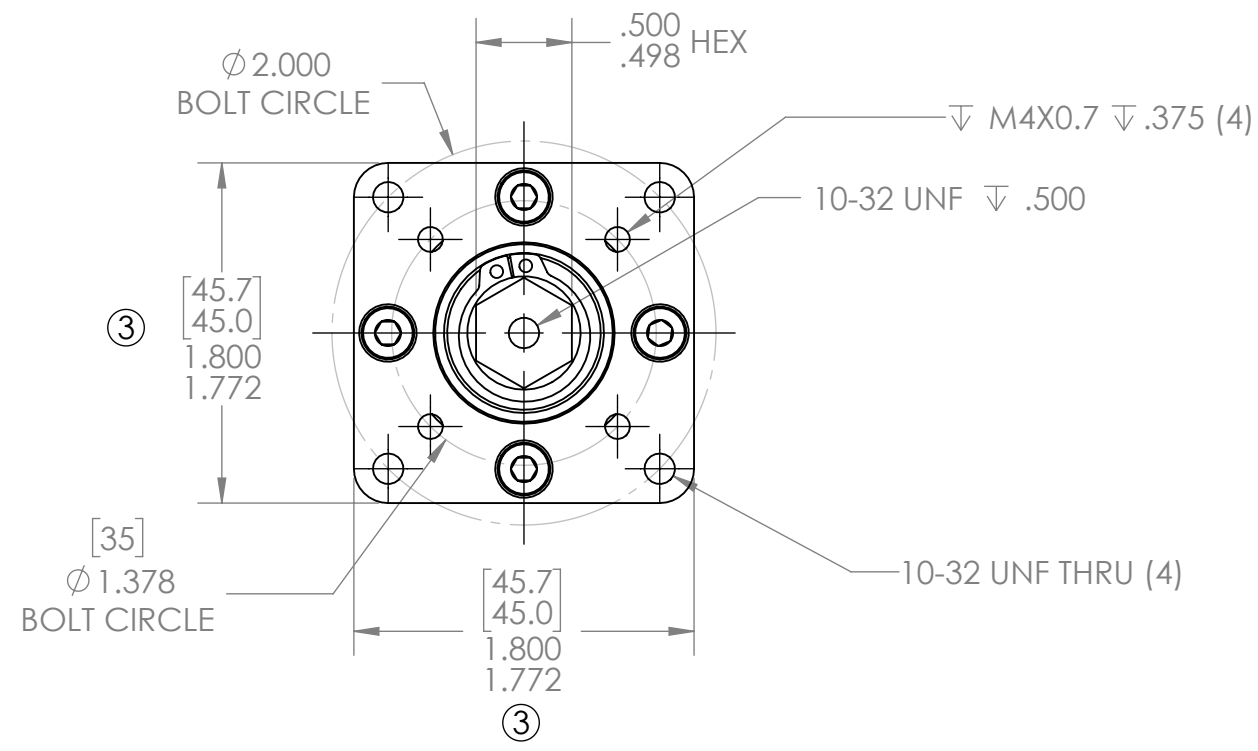
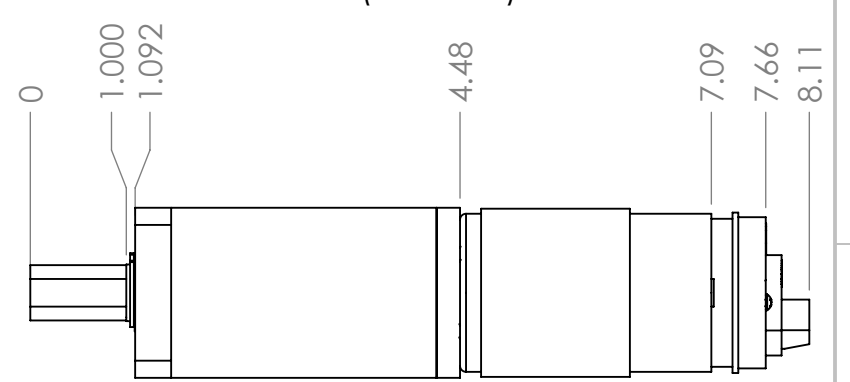
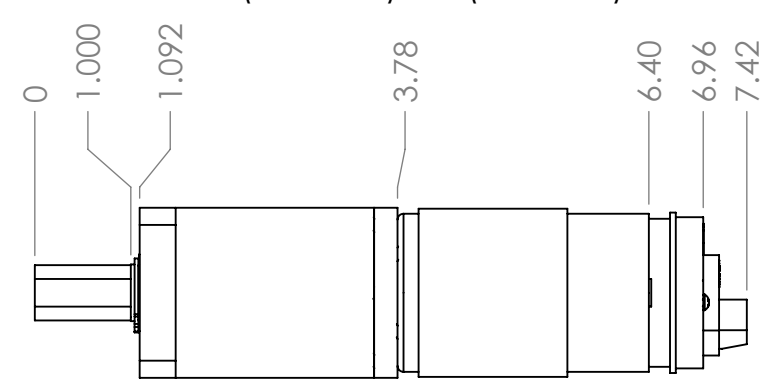
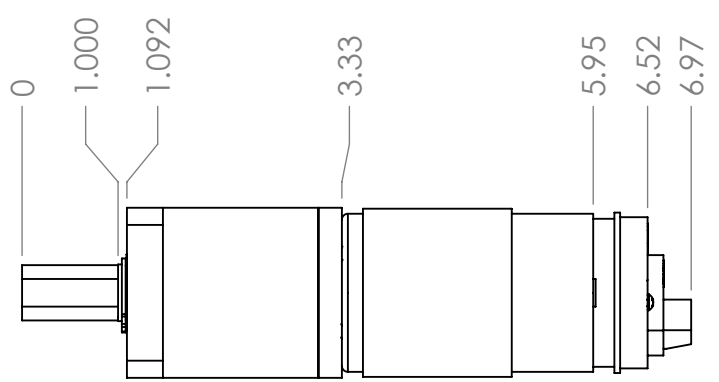
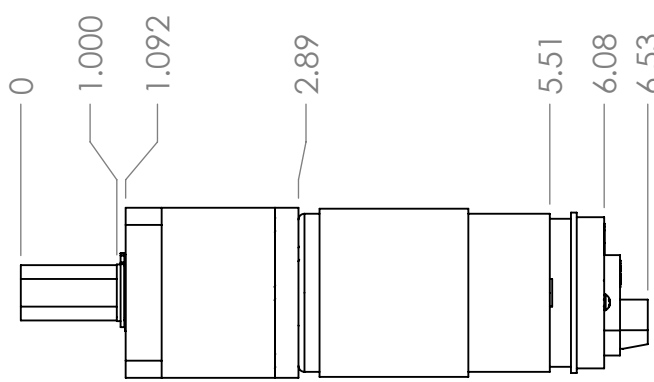

*** SEE CAD FOR ADDITIONAL TOOLPATH INFO***

UNLESS OTHERWISE SPECIFIED:		COMMENTS:			
DIMENSIONS ARE IN INCHES		DUAL DIMENSIONS ARE IN MILLIMETERS.			
TOLERANCES:		BREAK ALL SHARP EDGES.		TITLE:	
FRACTIONAL	±1/16			PG 500 HEX SERIES	
ANGULAR: MACH	±1°			W/MOTOR & ENCODER	
ANGULAR: BEND	±5°			SIZE	DWG. NO.
ONE PLACE DECIMAL	±0.1			B	
TWO PLACE DECIMAL	±0.01			SCALE: 1:2	SHEET 1 OF 4
THREE PLACE DECIMAL	±0.005				
FOUR PLACE DECIMAL	±0.0005				
MATERIAL		CHECKED	NAME	DATE	REV
		ENG APPR.	NM	2/3/21	2
FINISH		MFG APPR.			
DO NOT SCALE DRAWING		Q.A.			

4

3

2

1

B

B

A

A

4

3

2

1

REVISION HISTORY			
REV.	DESCRIPTION	DATE	DRAWN BY
1	ORIGINAL PRINT	11/8/2017	K. NEPOMUCENO



B

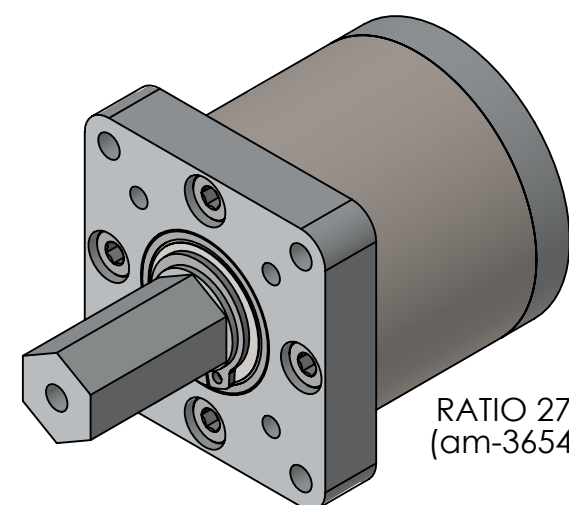

RATIO 27:1
(am-3654g)

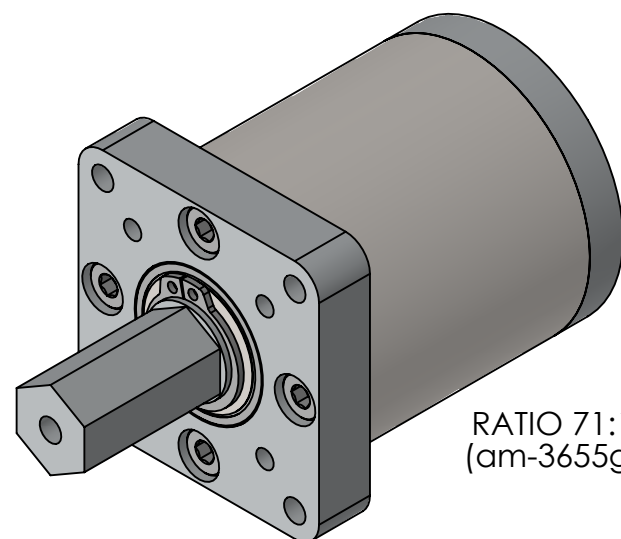

RATIO 71:1
(am-3655g)

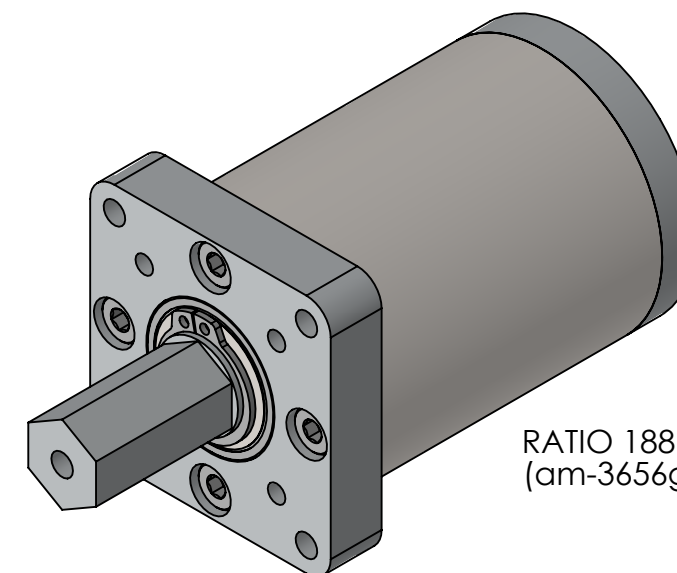

RATIO 188:1
(am-3656g)

B

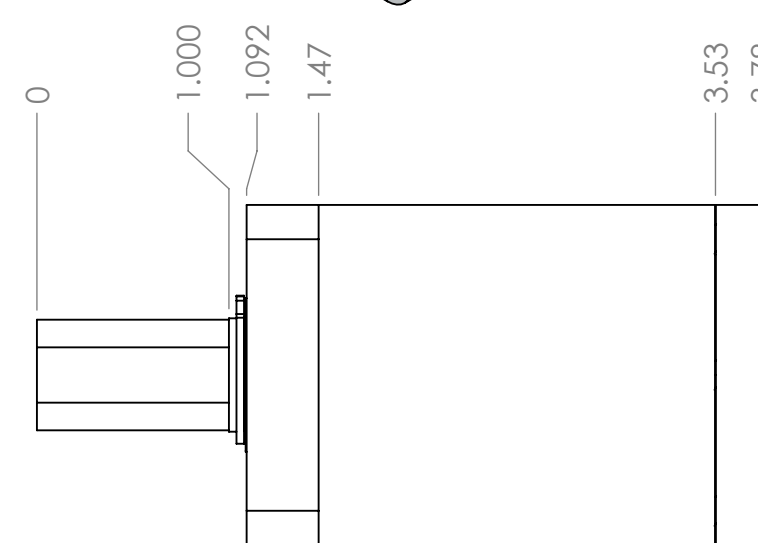
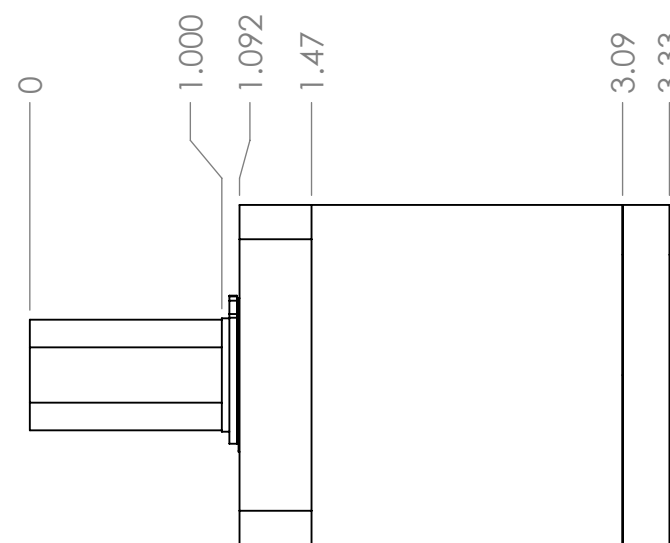
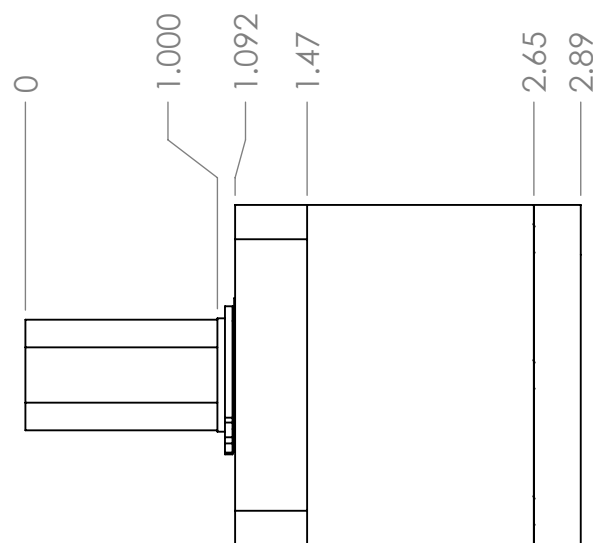

A

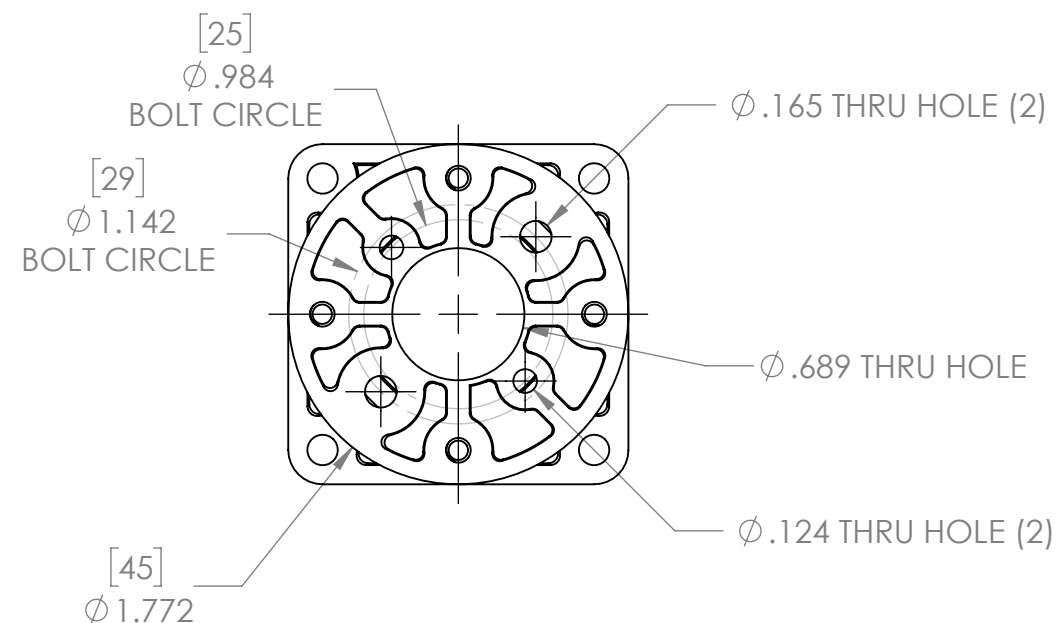

A

*** SEE CAD FOR ADDITIONAL TOOLPATH INFO***

UNLESS OTHERWISE SPECIFIED:		COMMENTS:			
DIMENSIONS ARE IN INCHES		DUAL DIMENSIONS ARE IN MILLIMETERS.			
TOLERANCES:		BREAK ALL SHARP EDGES.		TITLE:	
FRACTIONAL	±1/16			PG 500 HEX SERIES	
ANGULAR: MACH	±1°			GEARBOX ONLY	
ANGULAR: BEND	±5°			SIZE	DWG. NO.
ONE PLACE DECIMAL	±0.1	CHECKED	NAME	B	
TWO PLACE DECIMAL	±0.01	ENG APPR.	NM	11/9/17	REV
THREE PLACE DECIMAL	±0.005	MFG APPR.			2
FOUR PLACE DECIMAL	±0.0005	Q.A.			
MATERIAL				SCALE: 1:1	SHEET 2 OF 4
FINISH					
DO NOT SCALE DRAWING					

4

3

2

1

4

3

2

1

REVISION HISTORY			
REV.	DESCRIPTION	DATE	DRAWN BY
1	ORIGINAL PRINT	11/8/2017	K. NEPOMUCENO
2	UPDATED MOUNT FLANGE SIZE TOLERANCE	2/3/2021	N. LAWRENCE

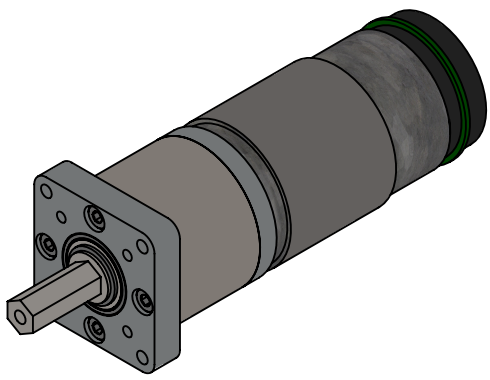

RATIO 27:1
(am-3651)

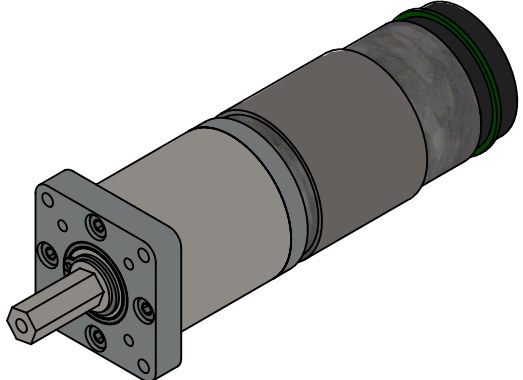

RATIO 71:1
(am-3652)

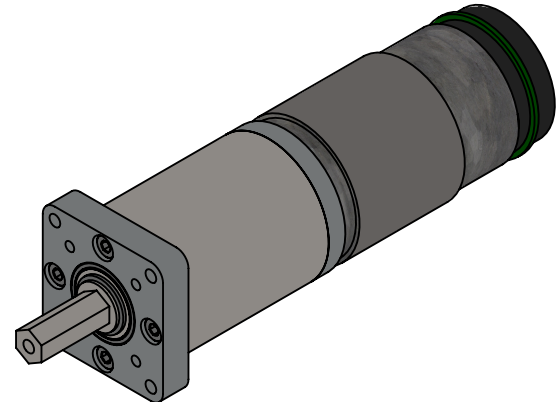

RATIO 188:1
(am-3653)

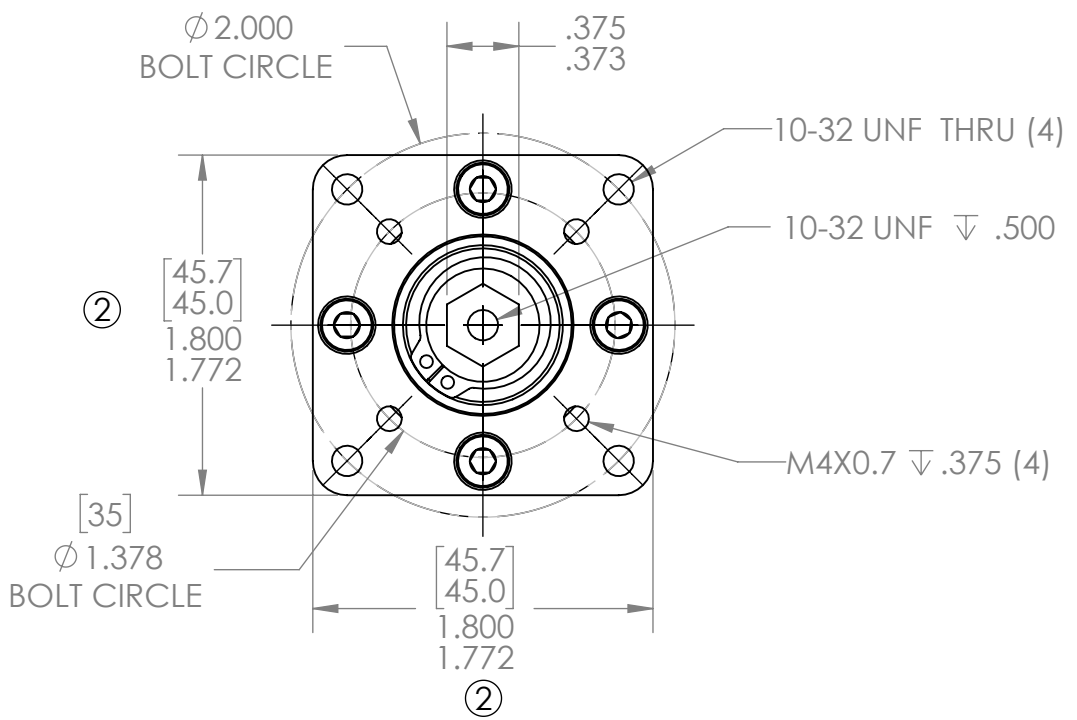
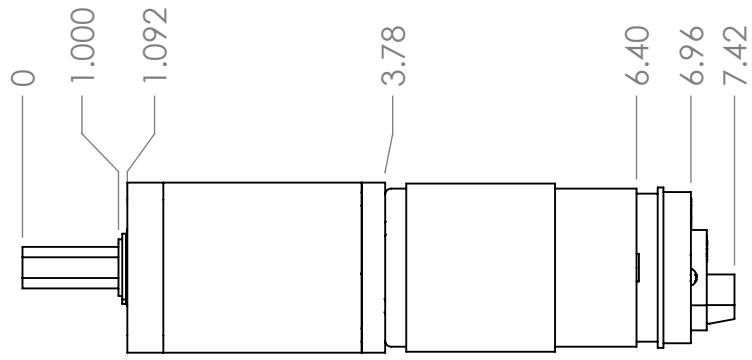
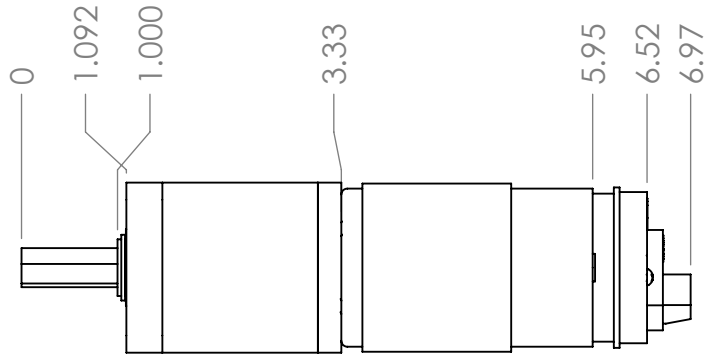
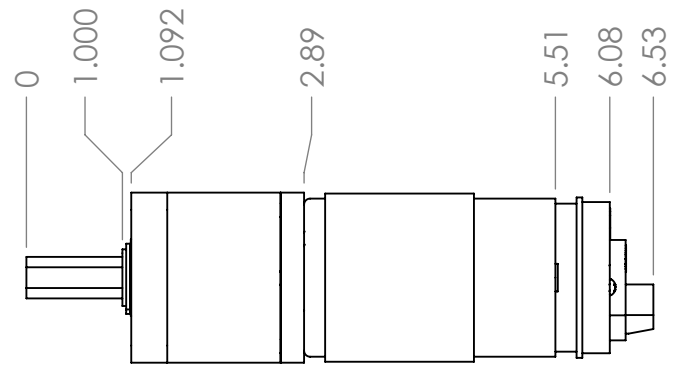

*** SEE CAD FOR ADDITIONAL TOOLPATH INFO***

UNLESS OTHERWISE SPECIFIED:		COMMENTS:				
DIMENSIONS ARE IN INCHES		DUAL DIMENSIONS ARE IN MILLIMETERS.				
TOLERANCES:		BREAK ALL SHARP EDGES.				
FRACTIONAL	±1/16	CHECKED	NAME	DATE	SIZE	DWG. NO.
ANGULAR: MACH	±1°	ENG APPR.	NM	2/3/21	B	
ANGULAR: BEND	±5°	MFG APPR.				REV 2
ONE PLACE DECIMAL	±0.1	Q.A.			SCALE: 1:1	SHEET 3 OF 4
TWO PLACE DECIMAL	±0.01					
THREE PLACE DECIMAL	±0.005					
FOUR PLACE DECIMAL	±0.0005					
MATERIAL						
FINISH						
DO NOT SCALE DRAWING						

4

3

2

1

B

B

A

A

4

3

2

1

REVISION HISTORY			
REV.	DESCRIPTION	DATE	DRAWN BY
1	ORIGINAL PRINT	11/8/2017	K. NEPOMUCENO

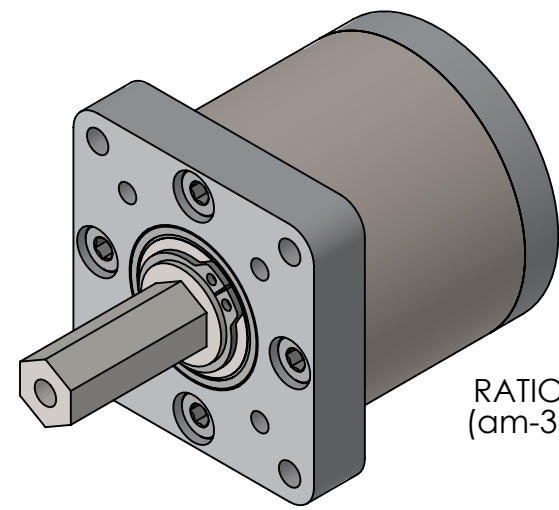

RATIO 27:1
(am-3651g)

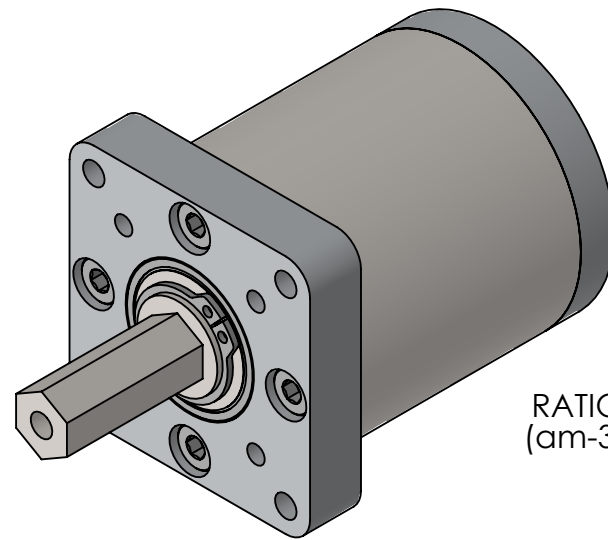

RATIO 71:1
(am-3652g)

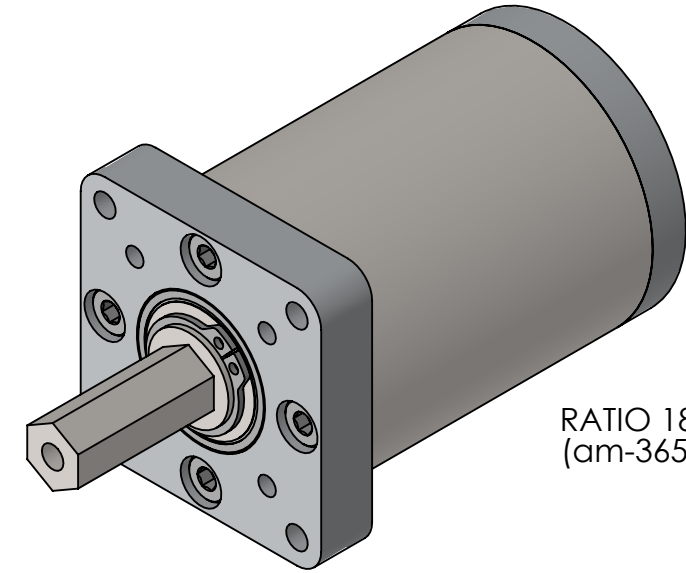

RATIO 188:1
(am-3653g)

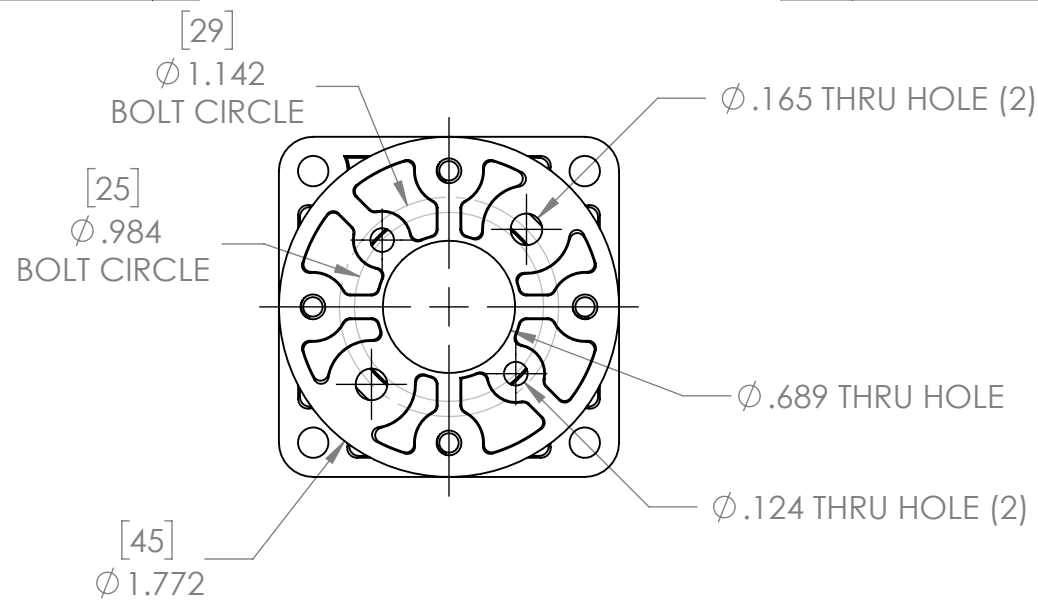
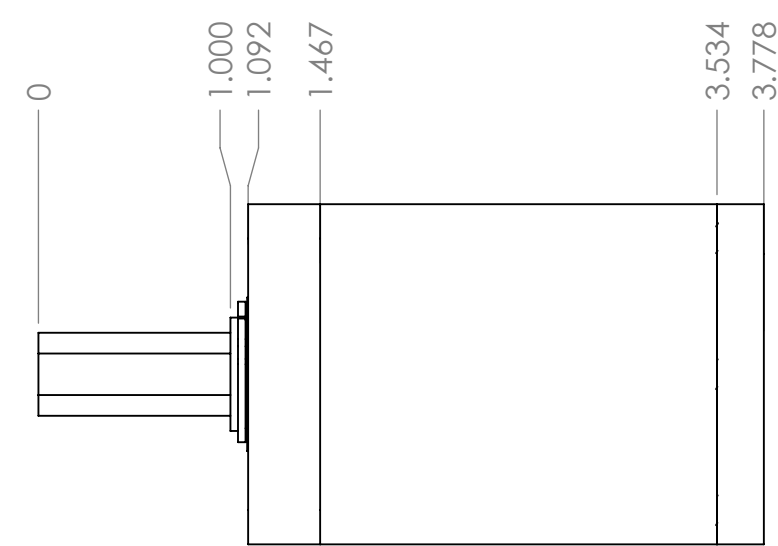
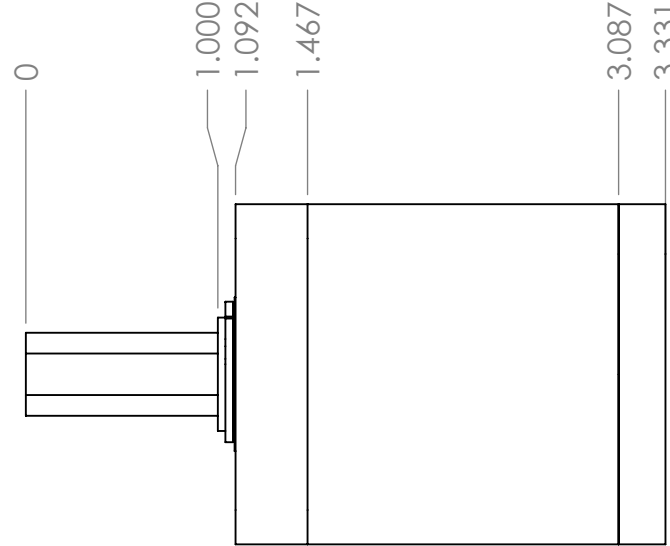
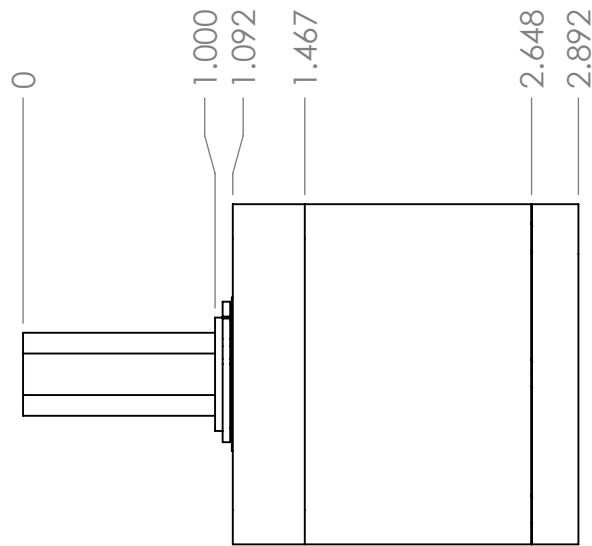

*** SEE CAD FOR ADDITIONAL TOOLPATH INFO***

UNLESS OTHERWISE SPECIFIED:		COMMENTS:			
DIMENSIONS ARE IN INCHES		DUAL DIMENSIONS ARE IN MILLIMETERS.			
TOLERANCES:		BREAK ALL SHARP EDGES.		TITLE: PG 375 HEX SERIES GEARBOX ONLY	
FRACTIONAL	$\pm 1/16$	CHECKED	NAME	DATE	SIZE
ANGULAR: MACH	$\pm 1^\circ$	ENG APPR.	NM	11/9/17	DWG. NO.
ANGULAR: BEND	$\pm 5^\circ$	MFG APPR.			REV
ONE PLACE DECIMAL	± 0.1	Q.A.			2
TWO PLACE DECIMAL	± 0.01				
THREE PLACE DECIMAL	± 0.005				
FOUR PLACE DECIMAL	± 0.0005				
MATERIAL		SCALE: 1:1		SHEET 4 OF 4	
FINISH					
DO NOT SCALE DRAWING					

4

3

2

1